

INSTALLATION & CARE



CUSTOM DASH AND REAR DECK COVER INSTALLATION

BEFORE INSTALLATION:

- Read entire installation instructions before proceeding
- Make sure dashboard is clean and dry
- Remember to give your dashboard time to conform. It will shape and fit perfectly after a few days.

1. Unroll Cover

Allow it to lie flat overnight if possible.

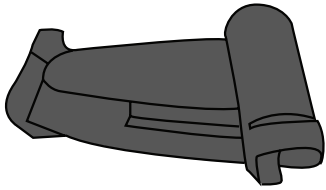

2. Clean Dashboard

Wipe off with a mild detergent to remove polish or wax from the areas where the fasteners will be placed.

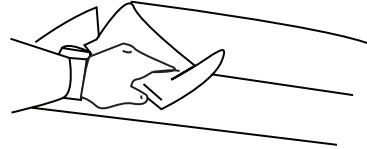

3. Pre-fit Cover on Dash

Align contours and cuts. Make sure the defrost vents (nearest windshield) align with the cutouts.

TIP: On some vehicles, the material must be pushed forward between the dash and windshield. Use a wooden ruler or paint stick if necessary.

4. Apply Fasteners

Remove cover from dash. Cut the fastener strip into 1-inch pieces and apply where needed. You may need a few fasteners near the windshield (on each side), several small pieces at the front edge and one or more in each contoured area. To remove fasteners, slowly peel to avoid damaging vinyl.

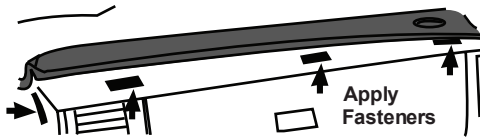

5. Pre-shape

Speed up the shaping process by bending or creasing the cover to help it conform to the curves of your dash.

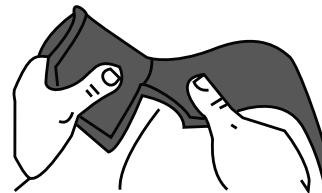

6. Apply Dash Cover

Realign the cover with fasteners and set it into place for the final time.

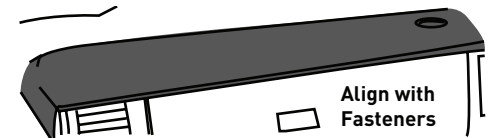

7. Custom Dash Cover Notices

AIRBAG

Your dashboard cover has been manufactured to allow for proper deployment of the airbag safety system. As designed, this product will not obstruct the airbag. You must not place any fasteners on this area, as doing so may obstruct deployment. Coverking assumes no responsibility for improper installation of dashboard covers, resulting in obstruction of airbag deployment.

FITMENT ISSUES

If your cover seems too big and hangs over the front of the dash, be sure the cover is pushed all the way back between the glass and front of the dash. The vent cutouts should match the defrost vents. If needed, use a wooden ruler or similar to push the cover back.

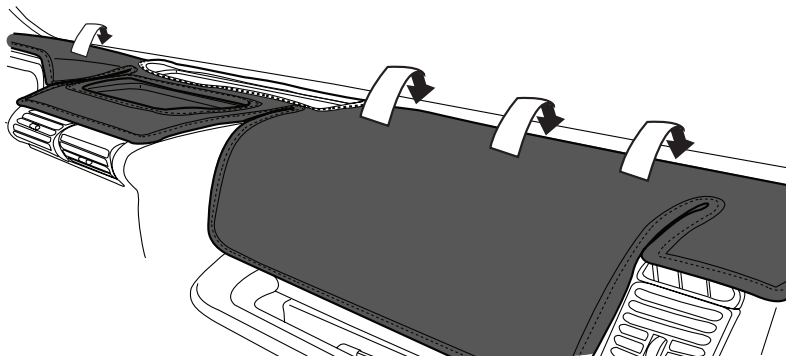

TIP: Because of auto assembly tolerances or variations in the position of replacement windshields, dash covers may require trimming on the windshield edge.

PLASTICIZER MIGRATION

This problem is common for certain car models. The plastic formulation inside the dashboard begins to break down, causing a darkened area to appear on the surface. This flaw may occur on both covered and uncovered dashboards. Coverking assumes no responsibility for such occurrences.